

Power Logic 8-BIT SHIFT REGISTER LED DRIVER

Check for Samples: [TLC6C598-Q1](#)

FEATURES

- Qualified for Automotive Applications
- AEC-Q100 Qualified With the Following Results:
 - Device Temperature Grade 1: -40°C to 125°C Ambient Operating Temperature Range
 - Device HBM ESD Classification Level H2
 - Device CDM ESD Classification Level C3B
- Wide V_{cc} From 3 V to 5.5 V
- Output Maximum Rating of 40 V
- Eight Power DMOS Transistor Outputs of 50-mA Continuous Current With $V_{cc} = 5\text{ V}$
- Thermal Shutdown Protection
- Enhanced Cascading for Multiple Stages
- All Registers Cleared With Single Input
- Low Power Consumption
- Slow Switching Time (t_r and t_f), Which Helps Significantly With Reducing EMI
- 16-Pin TSSOP-PW Package
- 16-Pin SOIC-D Package

APPLICATIONS

- Instrumentation Cluster
- Tell-Tale Lamps
- LED Illumination and Control

DESCRIPTION

The TLC6C598-Q1 is a monolithic, medium-voltage, low-current power 8-bit shift register designed for use in systems that require relatively moderate load power, such as LEDs.

This device contains an 8-bit serial-in, parallel-out shift register that feeds an 8-bit D-type storage register. Data transfers through both the shift and storage registers on the rising edge of the shift-register clock (SRCK) and the register clock (RCK), respectively. The storage register transfers data to the output buffer when shift register clear (CLR) is high. A low on CLR clears all registers in the device. Holding the output enable (\overline{G}) high, holds all data in the output buffers low, and all drain outputs are off. Holding \overline{G} low makes data from the storage register transparent to the output buffers. When data in the output buffers is low, the DMOS transistor outputs are off. When data is high, the DMOS transistor outputs have sink-current capability. The serial output (SER OUT) clocks out of the device on the falling edge of SRCK to provide additional hold time for cascaded applications. This provides improved performance for applications where clock signals may be skewed, devices are not located near one another, or the system must tolerate electromagnetic interference. The device contains built-in thermal shutdown protection.

Outputs are low-side, open-drain DMOS transistors with output ratings of 40 V and 50 mA continuous sink-current capabilities when $V_{cc} = 5\text{ V}$. The current limit decreases as the junction temperature increases for additional device protection. The device also provides up to 2000 V of ESD protection when tested using the human-body model and 200 V when using the machine model.

The TLC6C598-Q1 characterization is for for operation over the operating ambient temperature range of -40°C to 125°C .

APPLICATION SCHEMATIC

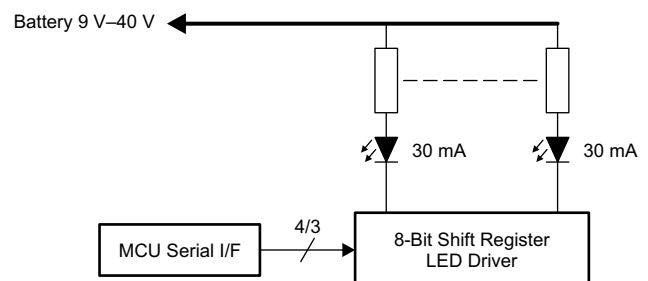

Figure 1. Typical Application Schematic



Please be aware that an important notice concerning availability, standard warranty, and use in critical applications of Texas Instruments semiconductor products and disclaimers thereto appears at the end of this data sheet.



These devices have limited built-in ESD protection. The leads should be shorted together or the device placed in conductive foam during storage or handling to prevent electrostatic damage to the MOS gates.

ORDERING INFORMATION

For the most-current package and ordering information, see the Package Option Addendum at the end of this document, or see the TI Web site at www.ti.com.

Logic Diagram (Positive Logic)

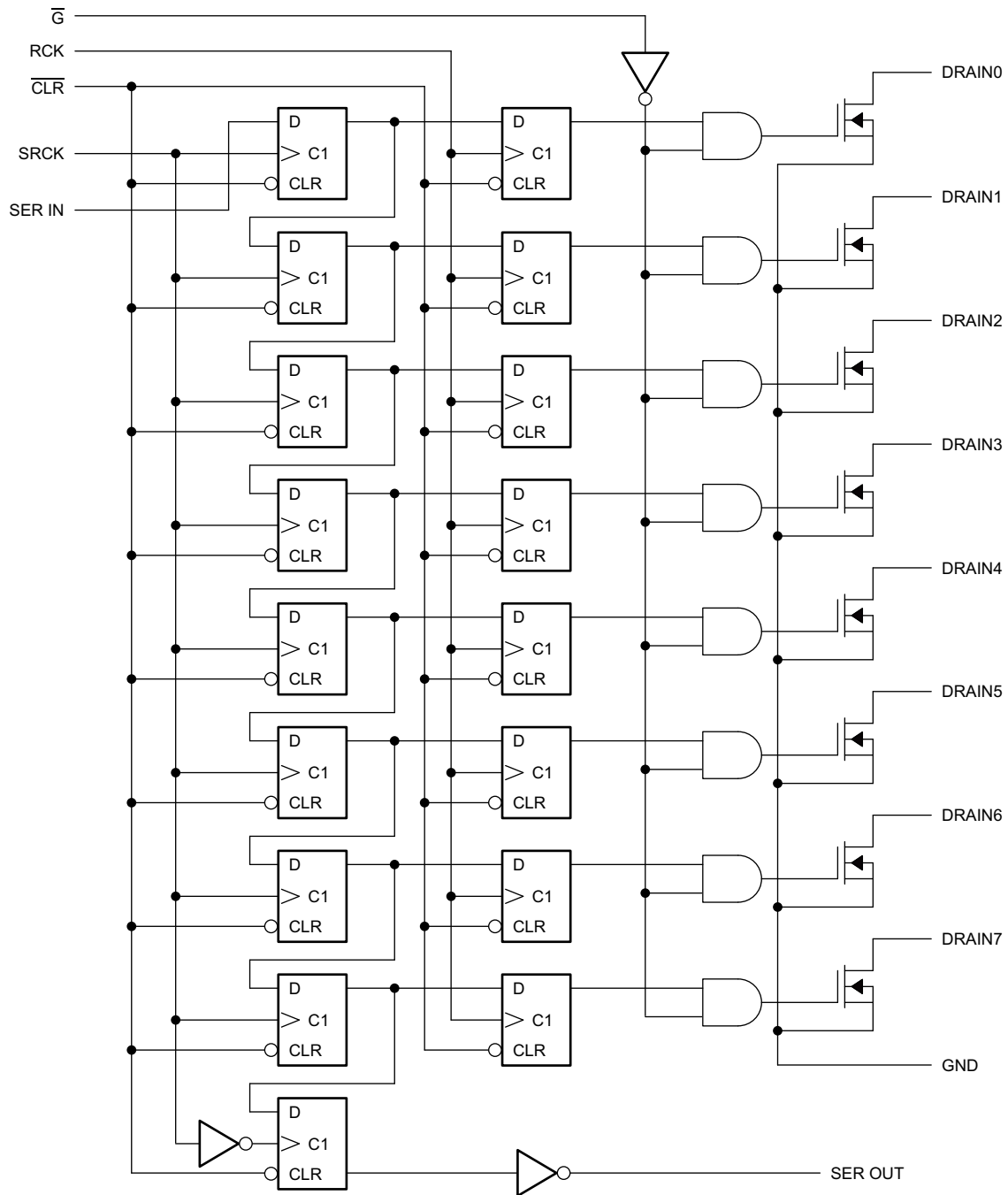

Figure 2. Logic Diagram of TLC6C598-Q1

ABSOLUTE MAXIMUM RATINGS

over operating free-air temperature range (unless otherwise noted)⁽¹⁾

		VALUE		
		MIN	MAX	UNIT
V _{CC}	Logic supply voltage	–0.3	8	V
V _I	Logic input-voltage range	–0.3	8	V
V _{DS}	Power DMOS drain-to-source voltage	–0.3	42	V
	Continuous total dissipation	See Thermal Information table		
ESD ⁽²⁾	Electrostatic discharge HBM		2	kV
T _A	Operating ambient temperature	–40	125	°C
T _{stg}	Storage temperature range	–55	165	°C
T _J	Operating junction temperature range	–40	150	°C

- (1) Stresses beyond those listed under *Absolute Maximum Ratings* may cause permanent damage to the device. These are stress ratings only, and functional operation of the device at these or any other conditions beyond those indicated under *Recommended Operating Conditions* is not implied. Exposure to absolute-maximum-rated conditions for extended periods may affect device reliability.
- (2) The human-body model is a 100-pF capacitor discharged through a 1.5-kΩ resistor into each pin.

THERMAL INFORMATION

THERMAL METRIC ⁽¹⁾		TLC6C598-Q1		UNIT
		PW (16 PINS)	D (16 PINS)	
θ _{JA}	Junction-to-ambient thermal resistance	129.4	100	°C/W
θ _{JCtop}	Junction-to-case (top) thermal resistance	55.4	45	°C/W
θ _{JB}	Junction-to-board thermal resistance	65.8	40	°C/W
ψ _{JT}	Junction-to-top characterization parameter	9.9	10	°C/W
ψ _{JB}	Junction-to-board characterization parameter	65.2	40	°C/W
θ _{JCbot}	Junction-to-case (bottom) thermal resistance	NA	NA	°C/W

- (1) For more information about traditional and new thermal metrics, see the *IC Package Thermal Metrics* application report, [SPRA953](#).

RECOMMENDED OPERATING CONDITIONS

		MIN	MAX	UNIT
V_{CC}	Supply voltage	3	5.5	V
V_{IH}	High-level input voltage	2.4		V
V_{IL}	Low-level input voltage		0.7	V
t_{su}	Setup time, SER IN high before SRCK \uparrow	15		ns
t_h	Hold time, SER IN high after SRCK \uparrow	15		ns
t_w	Pulse duration	40		ns
T_A	Operating ambient temperature	-40	125	°C

ELECTRICAL CHARACTERISTICS $V_{CC} = 5\text{ V}$, $T_C = 25^\circ\text{C}$ (unless otherwise noted)

PARAMETER	TEST CONDITIONS		MIN	TYP	MAX	UNIT	
	DRAIN0 to DRAIN7. Drain-to-source voltage				40	V	
V_{OH}	High-level output voltage, SER OUT	$I_{OH} = -20\ \mu\text{A}$	$V_{CC} = 5\text{ V}$	4.9	4.99	V	
		$I_{OH} = -4\ \text{mA}$		4.5	4.69	V	
V_{OL}	Low-level output voltage, SER OUT	$I_{OH} = 20\ \mu\text{A}$	$V_{CC} = 5\text{ V}$	0.001	0.01	V	
		$I_{OH} = 4\ \text{mA}$		0.25	0.4	V	
I_{IH}	High-level input current	$V_{CC} = 5\text{ V}$, $V_I = V_{CC}$		0.2		μA	
I_{IL}	Low-level input current	$V_{CC} = 5\text{ V}$, $V_I = 0$		-0.2		μA	
I_{CC}	Logic supply current	$V_{CC} = 5\text{ V}$, no clock signal	All outputs off	0.1	1	μA	
			All outputs on	88	160		
$I_{CC}(\text{FRQ})$	Logic supply current at frequency	$f_{SRCK} = 5\text{ MHz}$, $C_L = 30\text{ pF}$	All outputs on	200		μA	
I_{DSX}	Off-state drain current	$V_{DS} = 30\text{ V}$	$V_{CC} = 5\text{ V}$		0.1		
		$V_{DS} = 30\text{ V}$, $T_C = 125^\circ\text{C}$	$V_{CC} = 5\text{ V}$	0.15	0.3	μA	
$r_{DS(\text{on})}$	Static drain-source on-state resistance	$I_D = 20\ \text{mA}$, $V_{CC} = 5\text{ V}$, $T_A = 25^\circ\text{C}$, Single channel ON		6	7.41	8.6	Ω
		$I_D = 20\ \text{mA}$, $V_{CC} = 5\text{ V}$, $T_A = 25^\circ\text{C}$, All channels ON		6.7	8.3	9.6	
		$I_D = 20\ \text{mA}$, $V_{CC} = 3.3\text{ V}$, $T_A = 25^\circ\text{C}$, Single channel ON		7.9	9.34	11.2	
		$I_D = 20\ \text{mA}$, $V_{CC} = 3.3\text{ V}$, $T_A = 25^\circ\text{C}$, All channels ON		8.7	10.25	12.3	
		$I_D = 20\ \text{mA}$, $V_{CC} = 5\text{ V}$, $T_A = 125^\circ\text{C}$, Single channel ON		9.1	11.13	12.9	
		$I_D = 20\ \text{mA}$, $V_{CC} = 5\text{ V}$, $T_A = 125^\circ\text{C}$, All channels ON		10.3	12.28	14.5	
		$I_D = 20\ \text{mA}$, $V_{CC} = 3.3\text{ V}$, $T_A = 125^\circ\text{C}$, Single channel ON		11.6	13.69	16.4	
		$I_D = 20\ \text{mA}$, $V_{CC} = 3.3\text{ V}$, $T_A = 125^\circ\text{C}$, All channels ON		12.8	14.89	18.2	
$T_{SHUTDOWN}$	Thermal shutdown trip point		150	175	200	°C	
T_{hys}	Hysteresis			15		°C	

SWITCHING CHARACTERISTICS
 $V_{CC} = 5\text{ V}$, $T_J = 25^\circ\text{C}$

PARAMETER		TEST CONDITIONS	MIN	TYP	MAX	UNIT
t_{PLH}	Propagation delay time, low-to-high-level output from \overline{G}	$C_L = 30\text{ pF}$, $I_D = 48\text{ mA}$; see		220		ns
t_{PHL}	Propagation delay time, high-to-low-level output from \overline{G}			75		ns
t_r	Rise time, drain output			210		ns
t_f	Fall time, drain output			128		ns
t_{pd}	Propagation delay time, SRCK \downarrow to SEROUT	$C_L = 30\text{ pF}$, $I_D = 48\text{ mA}$		49.4		ns
t_{or}	SEROUT rise time (10% to 90%)	$C_L = 30\text{ pF}$		20		ns
t_{of}	SEROUT fall time (90% to 10%)	$C_L = 30\text{ pF}$		20		ns
$f_{(SRCK)}$	Serial clock frequency	$C_L = 30\text{ pF}$, $I_D = 20\text{ mA}$			10	MHz
t_{SRCK_WH}	SRCK pulse duration, high		30			ns
t_{SRCK_WL}	SRCK pulse duration, low		30			ns

DEVICE INFORMATION

PIN CONFIGURATIONS

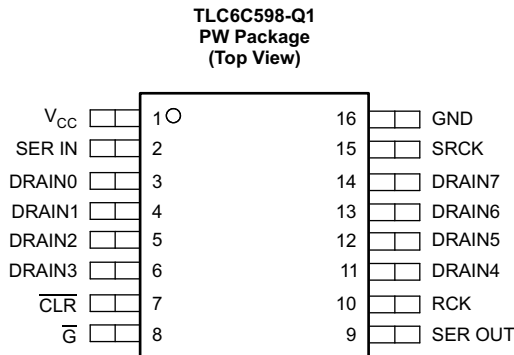

Figure 3. PW-Package Pin Configuration of TLC6C598-Q1

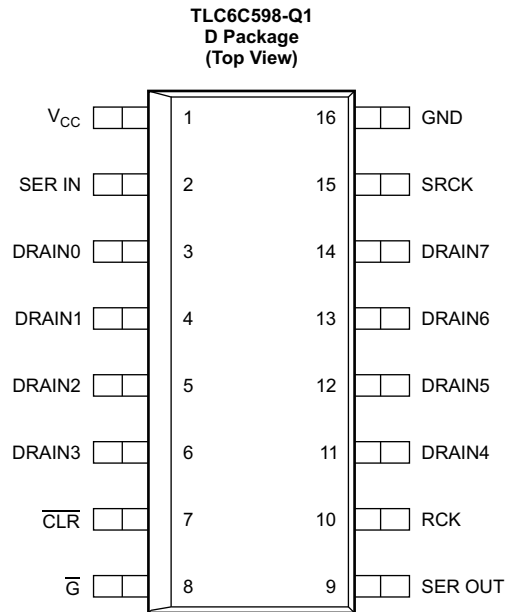

Figure 4. D-Package Pin Configuration of TLC6C598-Q1

PIN FUNCTIONS

NAME	NO.	I/O	DESCRIPTION
CLR	7	I	Shift register clear, active-low
DRAIN0	3	O	Open-drain output
DRAIN1	4	O	Open-drain output
DRAIN2	5	O	Open-drain output
DRAIN3	6	O	Open-drain output
DRAIN4	11	O	Open-drain output
DRAIN5	12	O	Open-drain output
DRAIN6	13	O	Open-drain output
DRAIN7	14	O	Open-drain output
G-bar	8	I	Output enable, active-low
GND	16	—	Power ground
RCK	10	I	Register clock
SER IN	2	I	Serial data input
SER OUT	9	O	Serial data output
SRCK	15	I	Shift register clock
VCC	1	I	Power supply

PIN DESCRIPTIONS

CLR is the signal used to clear all the registers. The storage register transfers data to the output buffer when shift register clear (CLR) is high. Driving CLR low clears all the registers in the device.

DRAIN0–DRAIN7 are the LED current-sink channels. These pins connect to LED cathodes, and can survive up to 40-V LED supply voltage. This is quite helpful during automotive load-dump conditions.

$\overline{\text{G}}$ is the LED-channel enable and disable input pin. Having $\overline{\text{G}}$ low enables all drain channels according to the output-latch register content. When high, all channels are off.

GND is the ground reference pin for the device. This pin must connect to the ground plane on the PCB.

RCK is the storage-register clock. The data in each shift register stage transfers to the storage register at the rising edge of RCK. Data in the storage register appears at the output whenever the output enable ($\overline{\text{G}}$) input signal is high.

SER IN is the serial data input. Data on SER IN loads into the internal register on each rising edge of SRCK.

SER OUT is the serial data output of the 8-bit serial shift register. The purpose of this pin is to cascade several devices on the serial bus. By connecting the SER OUT pin to the SER IN input of the next device on the serial bus to cascade, the data transfers to the next device on the falling edge of SRCK. This can improve the cascade application reliability, as it can avoid the issue that the second device receives SRCK and data input at the same rising edge of SRCK.

SRCK is the serial clock input. On each rising SRCK edge, data transfers from SER IN to the internal serial shift registers.

V_{CC} is the power-supply pin voltage for the device. TI recommends adding a 0.1- μF ceramic capacitor close to the pin.

THERMAL SHUTDOWN

The device implements an internal thermal shutdown to protect itself if the junction temperature exceeds 175°C (typical). The thermal shutdown forces the device to have an open state when the junction temperature exceeds the thermal trip threshold. Once the junction temperature decreases below 160°C (typical), the device begins to operate again.

APPLICATION INFORMATION

Figure 5 shows a typical cascade application circuit with two TLC6C598-Q1 chips configured to cascade topology. The MCU generates all the input signals.

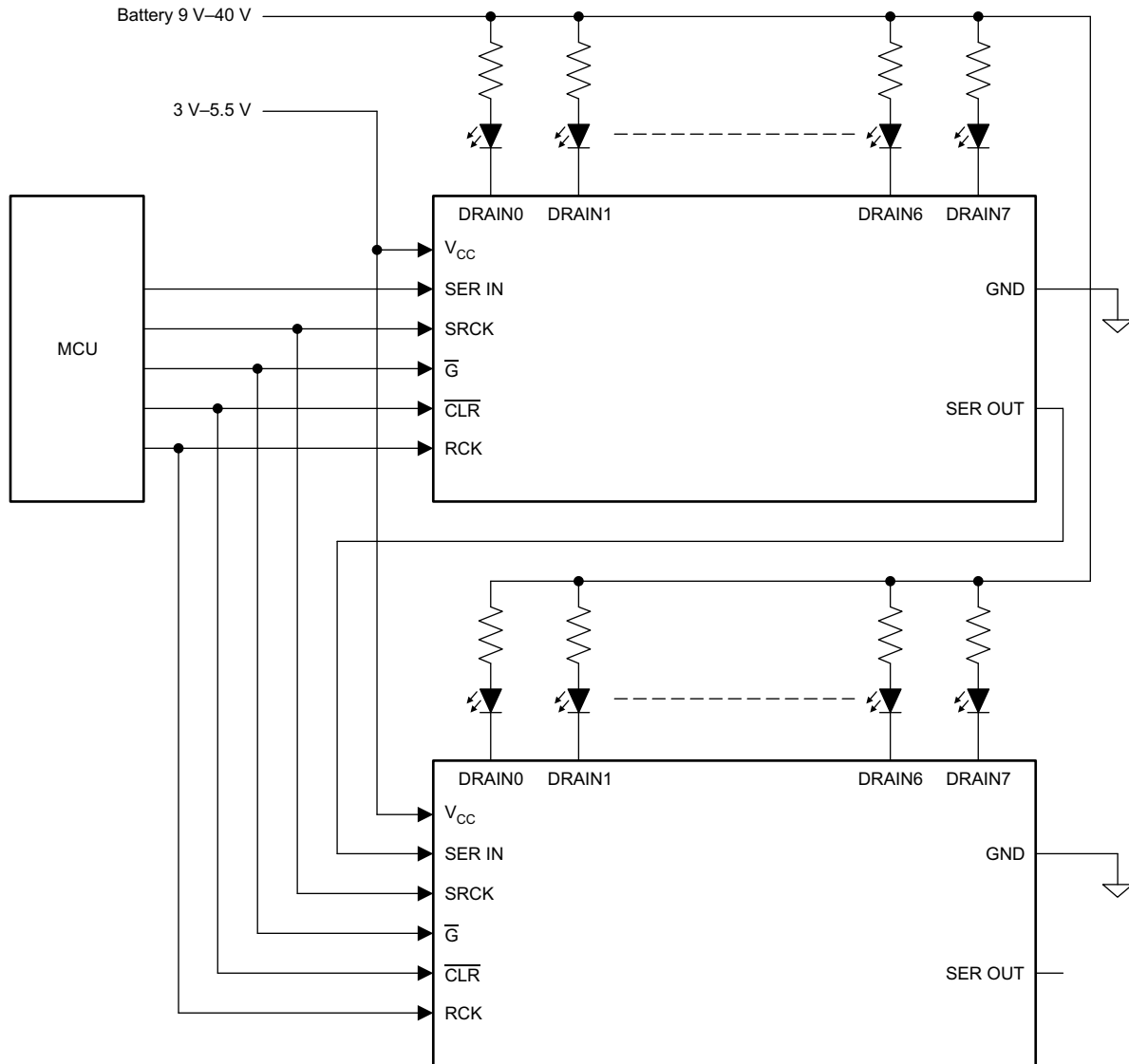
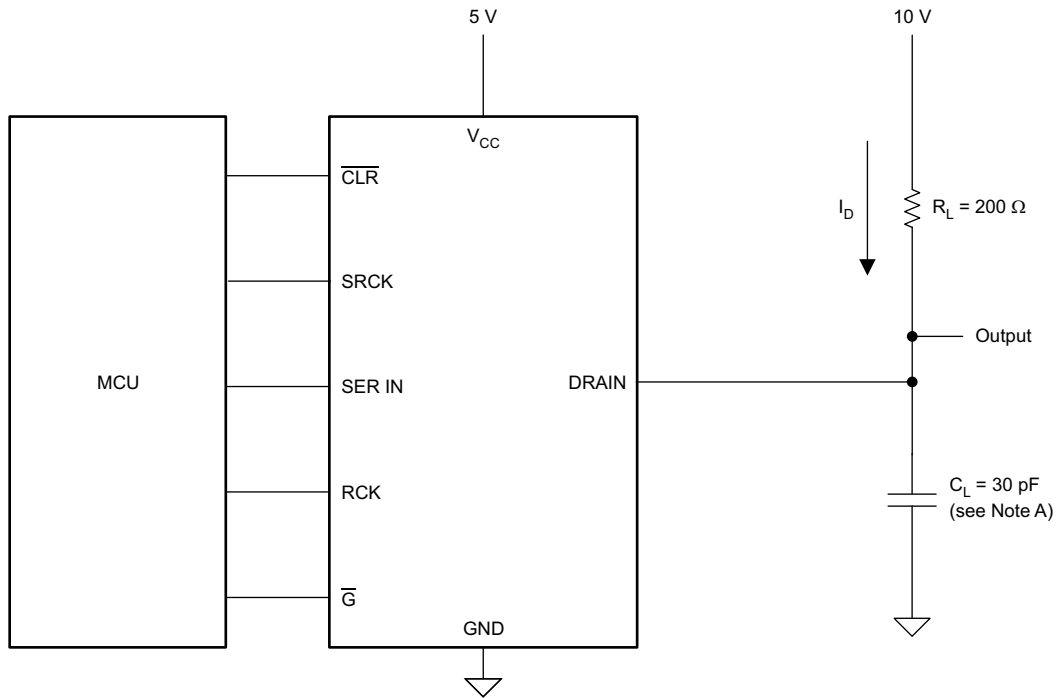

Figure 5. Typical Application Circuit

PARAMETER MEASUREMENT INFORMATION

Figure 6 and Figure 7 show the resistive-load test circuit and voltage waveforms. One can see from Figure 7 that with G held low and CLR held high, the status of each drain changes on the rising edge of the register clock, indicating the transfer of data to the output buffers at that time.

PARAMETER MEASUREMENT INFORMATION (continued)



A. C_L includes probe and jig capacitance.

Figure 6. Resistive-Load Test Circuit

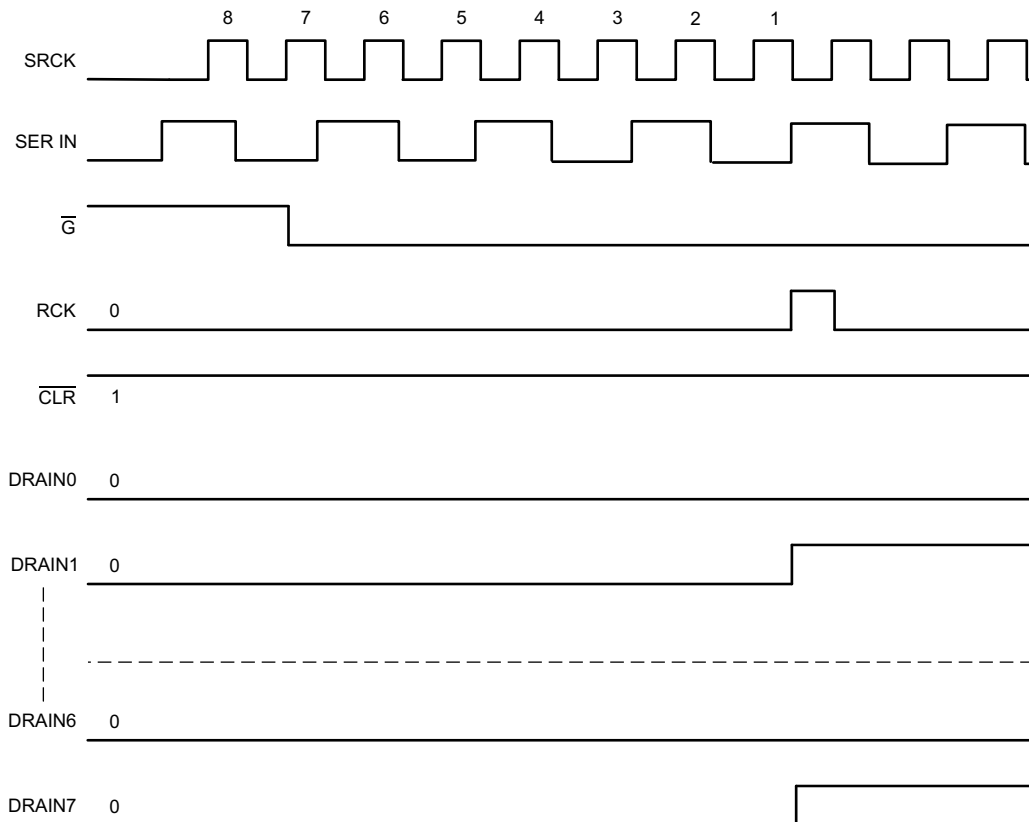

Figure 7. Voltage Waveforms

PARAMETER MEASUREMENT INFORMATION (continued)

Timing Waveform

Figure 8 shows the SER IN to SER OUT waveform. The output signal appears on the falling edge of the shift register clock (SRCK) because there is a phase inverter at SER OUT (see Figure 2). As a result, it takes seven and a half periods of SRCK for data to transfer from SER IN to SER OUT.

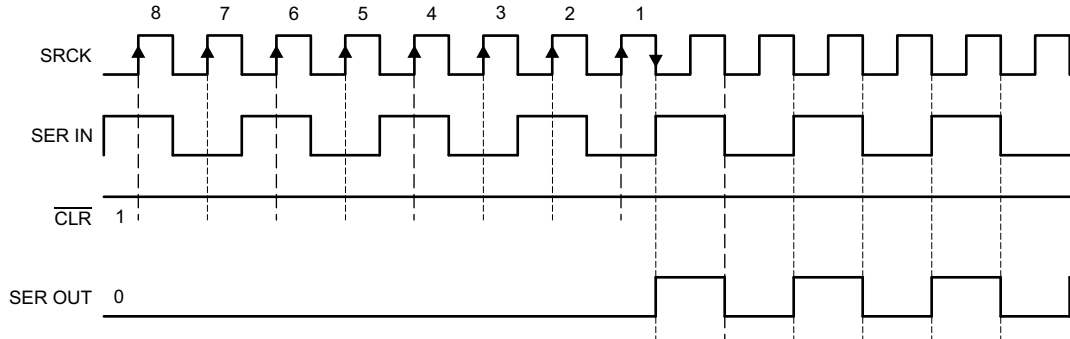

Figure 8. SER IN to SER OUT Waveform

Figure 9 shows the switching times and voltage waveforms. Tests for all these parameters took place using the test circuit shown in Figure 6.

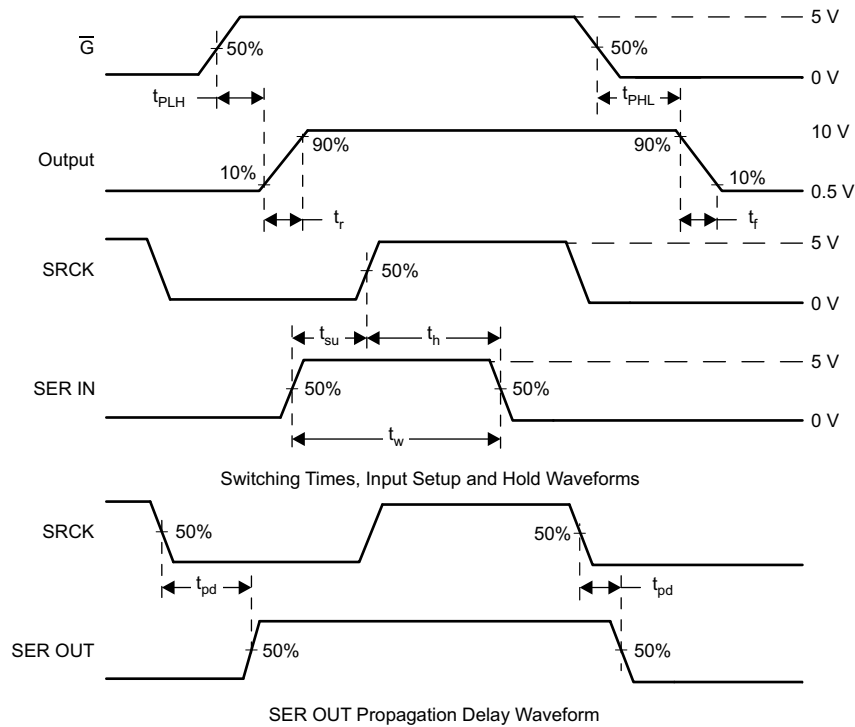

Figure 9. Switching Times and Voltage Waveforms

TYPICAL CHARACTERISTICS

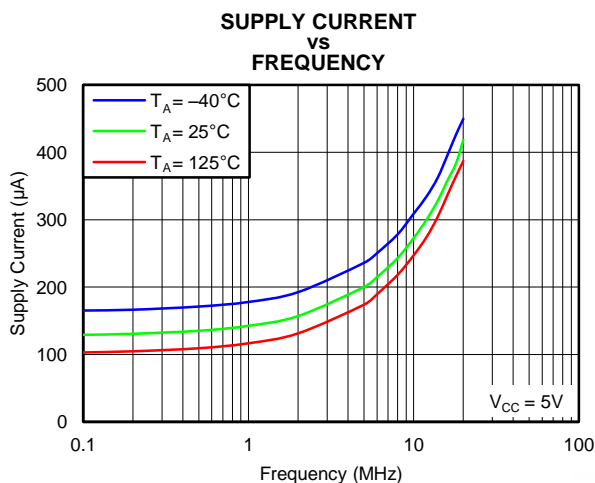

Figure 10.

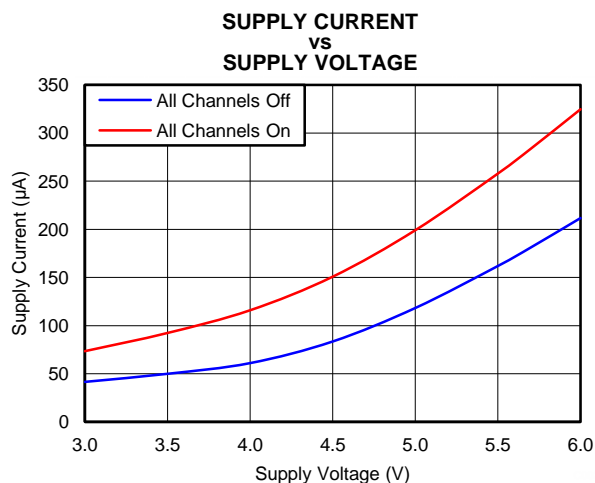

Figure 11.

Conditions for Figure 12 and Figure 13: Single channel on

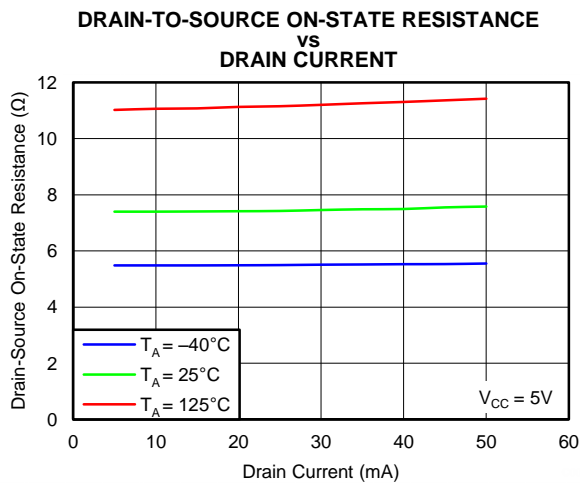

Figure 12.

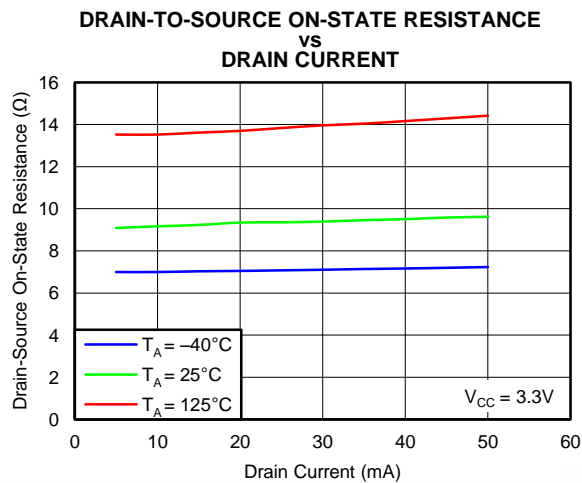

Figure 13.

TYPICAL CHARACTERISTICS

Conditions for Figure 14, Figure 15 and Figure 16: All channels on

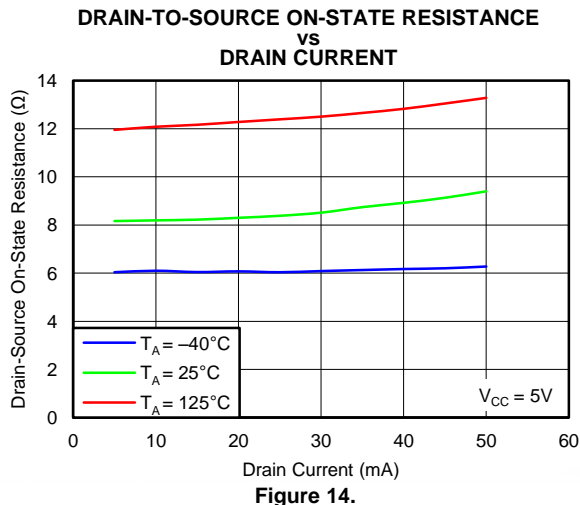

Figure 14.

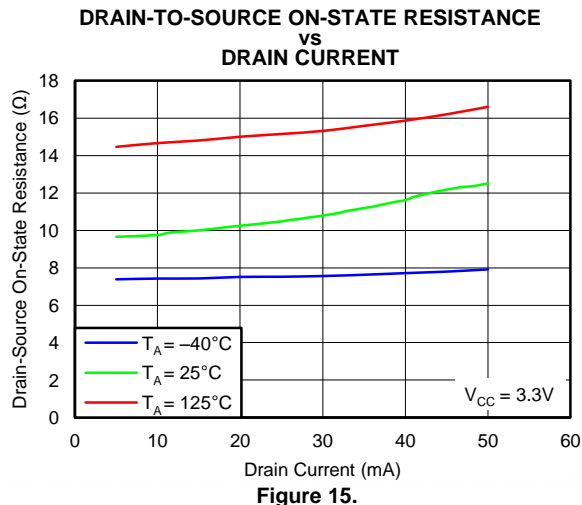
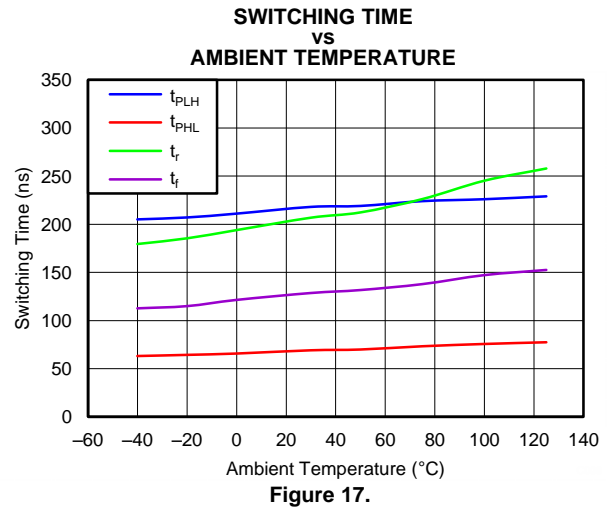
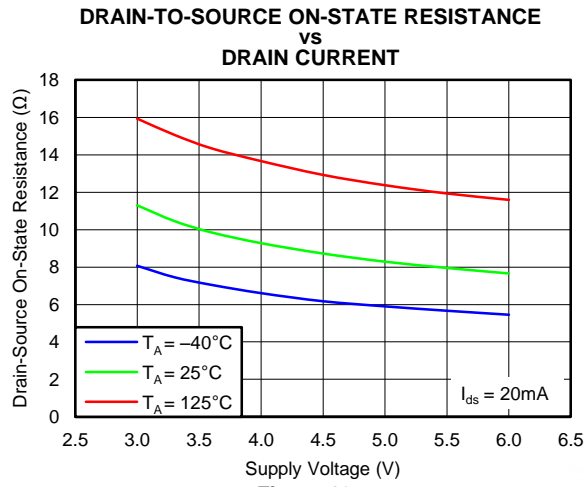

Figure 15.

TYPICAL CHARACTERISTICS (continued)

Conditions for Figure 14, Figure 15 and Figure 16: All channels on



PACKAGING INFORMATION

Orderable Device	Status (1)	Package Type	Package Drawing	Pins	Package Qty	Eco Plan (2)	Lead/Ball Finish	MSL Peak Temp (3)	Op Temp (°C)	Device Marking (4/5)	Samples
TLC6C598QDRQ1	ACTIVE	SOIC	D	16	2500	Green (RoHS & no Sb/Br)	CU NIPDAU	Level-3-260C-168 HR	-40 to 125	TLC6C598	Samples
TLC6C598QPWRQ1	ACTIVE	TSSOP	PW	16	2000	Green (RoHS & no Sb/Br)	CU NIPDAU	Level-3-260C-168 HR	-40 to 125	6C598	Samples

(1) The marketing status values are defined as follows:

ACTIVE: Product device recommended for new designs.

LIFEBUY: TI has announced that the device will be discontinued, and a lifetime-buy period is in effect.

NRND: Not recommended for new designs. Device is in production to support existing customers, but TI does not recommend using this part in a new design.

PREVIEW: Device has been announced but is not in production. Samples may or may not be available.

OBSOLETE: TI has discontinued the production of the device.

(2) Eco Plan - The planned eco-friendly classification: Pb-Free (RoHS), Pb-Free (RoHS Exempt), or Green (RoHS & no Sb/Br) - please check <http://www.ti.com/productcontent> for the latest availability information and additional product content details.

TBD: The Pb-Free/Green conversion plan has not been defined.

Pb-Free (RoHS): TI's terms "Lead-Free" or "Pb-Free" mean semiconductor products that are compatible with the current RoHS requirements for all 6 substances, including the requirement that lead not exceed 0.1% by weight in homogeneous materials. Where designed to be soldered at high temperatures, TI Pb-Free products are suitable for use in specified lead-free processes.

Pb-Free (RoHS Exempt): This component has a RoHS exemption for either 1) lead-based flip-chip solder bumps used between the die and package, or 2) lead-based die adhesive used between the die and leadframe. The component is otherwise considered Pb-Free (RoHS compatible) as defined above.

Green (RoHS & no Sb/Br): TI defines "Green" to mean Pb-Free (RoHS compatible), and free of Bromine (Br) and Antimony (Sb) based flame retardants (Br or Sb do not exceed 0.1% by weight in homogeneous material)

(3) MSL, Peak Temp. -- The Moisture Sensitivity Level rating according to the JEDEC industry standard classifications, and peak solder temperature.

(4) There may be additional marking, which relates to the logo, the lot trace code information, or the environmental category on the device.

(5) Multiple Device Markings will be inside parentheses. Only one Device Marking contained in parentheses and separated by a "~" will appear on a device. If a line is indented then it is a continuation of the previous line and the two combined represent the entire Device Marking for that device.

Important Information and Disclaimer: The information provided on this page represents TI's knowledge and belief as of the date that it is provided. TI bases its knowledge and belief on information provided by third parties, and makes no representation or warranty as to the accuracy of such information. Efforts are underway to better integrate information from third parties. TI has taken and continues to take reasonable steps to provide representative and accurate information but may not have conducted destructive testing or chemical analysis on incoming materials and chemicals. TI and TI suppliers consider certain information to be proprietary, and thus CAS numbers and other limited information may not be available for release.

In no event shall TI's liability arising out of such information exceed the total purchase price of the TI part(s) at issue in this document sold by TI to Customer on an annual basis.

TAPE AND REEL INFORMATION



QUADRANT ASSIGNMENTS FOR PIN 1 ORIENTATION IN TAPE



*All dimensions are nominal

Device	Package Type	Package Drawing	Pins	SPQ	Reel Diameter (mm)	Reel Width W1 (mm)	A0 (mm)	B0 (mm)	K0 (mm)	P1 (mm)	W (mm)	Pin1 Quadrant
TLC6C598QPWRQ1	TSSOP	PW	16	2000	330.0	12.4	6.9	5.6	1.6	8.0	12.0	Q1

TAPE AND REEL BOX DIMENSIONS



*All dimensions are nominal

Device	Package Type	Package Drawing	Pins	SPQ	Length (mm)	Width (mm)	Height (mm)
TLC6C598QPWRQ1	TSSOP	PW	16	2000	367.0	367.0	35.0

D (R-PDSO-G16)

PLASTIC SMALL OUTLINE



- NOTES:
- A. All linear dimensions are in inches (millimeters).
 - B. This drawing is subject to change without notice.
 -  C. Body length does not include mold flash, protrusions, or gate burrs. Mold flash, protrusions, or gate burrs shall not exceed 0.006 (0,15) each side.
 -  D. Body width does not include interlead flash. Interlead flash shall not exceed 0.017 (0,43) each side.
 - E. Reference JEDEC MS-012 variation AC.

D (R-PDSO-G16)

PLASTIC SMALL OUTLINE



- NOTES:
- All linear dimensions are in millimeters.
 - This drawing is subject to change without notice.
 - Publication IPC-7351 is recommended for alternate designs.
 - Laser cutting apertures with trapezoidal walls and also rounding corners will offer better paste release. Customers should contact their board assembly site for stencil design recommendations. Refer to IPC-7525 for other stencil recommendations.
 - Customers should contact their board fabrication site for solder mask tolerances between and around signal pads.

PW (R-PDSO-G16)

PLASTIC SMALL OUTLINE

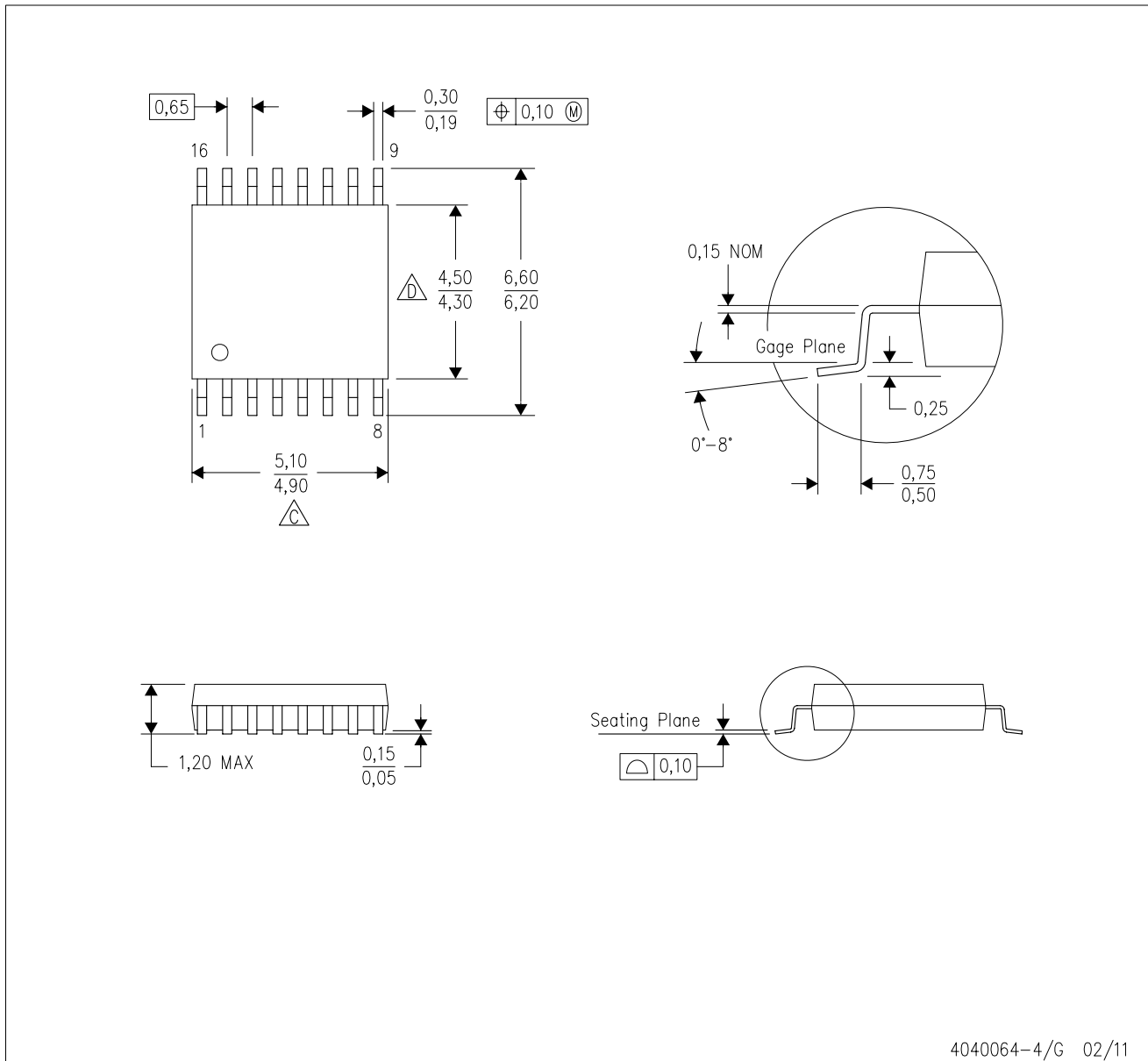

4040064-4/G 02/11

- NOTES:
- A. All linear dimensions are in millimeters. Dimensioning and tolerancing per ASME Y14.5M-1994.
 - B. This drawing is subject to change without notice.
 -  Body length does not include mold flash, protrusions, or gate burrs. Mold flash, protrusions, or gate burrs shall not exceed 0,15 each side.
 -  Body width does not include interlead flash. Interlead flash shall not exceed 0,25 each side.
 - E. Falls within JEDEC MO-153

IMPORTANT NOTICE

Texas Instruments Incorporated and its subsidiaries (TI) reserve the right to make corrections, enhancements, improvements and other changes to its semiconductor products and services per JESD46, latest issue, and to discontinue any product or service per JESD48, latest issue. Buyers should obtain the latest relevant information before placing orders and should verify that such information is current and complete. All semiconductor products (also referred to herein as "components") are sold subject to TI's terms and conditions of sale supplied at the time of order acknowledgment.

TI warrants performance of its components to the specifications applicable at the time of sale, in accordance with the warranty in TI's terms and conditions of sale of semiconductor products. Testing and other quality control techniques are used to the extent TI deems necessary to support this warranty. Except where mandated by applicable law, testing of all parameters of each component is not necessarily performed.

TI assumes no liability for applications assistance or the design of Buyers' products. Buyers are responsible for their products and applications using TI components. To minimize the risks associated with Buyers' products and applications, Buyers should provide adequate design and operating safeguards.

TI does not warrant or represent that any license, either express or implied, is granted under any patent right, copyright, mask work right, or other intellectual property right relating to any combination, machine, or process in which TI components or services are used. Information published by TI regarding third-party products or services does not constitute a license to use such products or services or a warranty or endorsement thereof. Use of such information may require a license from a third party under the patents or other intellectual property of the third party, or a license from TI under the patents or other intellectual property of TI.

Reproduction of significant portions of TI information in TI data books or data sheets is permissible only if reproduction is without alteration and is accompanied by all associated warranties, conditions, limitations, and notices. TI is not responsible or liable for such altered documentation. Information of third parties may be subject to additional restrictions.

Resale of TI components or services with statements different from or beyond the parameters stated by TI for that component or service voids all express and any implied warranties for the associated TI component or service and is an unfair and deceptive business practice. TI is not responsible or liable for any such statements.

Buyer acknowledges and agrees that it is solely responsible for compliance with all legal, regulatory and safety-related requirements concerning its products, and any use of TI components in its applications, notwithstanding any applications-related information or support that may be provided by TI. Buyer represents and agrees that it has all the necessary expertise to create and implement safeguards which anticipate dangerous consequences of failures, monitor failures and their consequences, lessen the likelihood of failures that might cause harm and take appropriate remedial actions. Buyer will fully indemnify TI and its representatives against any damages arising out of the use of any TI components in safety-critical applications.

In some cases, TI components may be promoted specifically to facilitate safety-related applications. With such components, TI's goal is to help enable customers to design and create their own end-product solutions that meet applicable functional safety standards and requirements. Nonetheless, such components are subject to these terms.

No TI components are authorized for use in FDA Class III (or similar life-critical medical equipment) unless authorized officers of the parties have executed a special agreement specifically governing such use.

Only those TI components which TI has specifically designated as military grade or "enhanced plastic" are designed and intended for use in military/aerospace applications or environments. Buyer acknowledges and agrees that any military or aerospace use of TI components which have **not** been so designated is solely at the Buyer's risk, and that Buyer is solely responsible for compliance with all legal and regulatory requirements in connection with such use.

TI has specifically designated certain components as meeting ISO/TS16949 requirements, mainly for automotive use. In any case of use of non-designated products, TI will not be responsible for any failure to meet ISO/TS16949.

Products

Audio	www.ti.com/audio
Amplifiers	amplifier.ti.com
Data Converters	dataconverter.ti.com
DLP® Products	www.dlp.com
DSP	dsp.ti.com
Clocks and Timers	www.ti.com/clocks
Interface	interface.ti.com
Logic	logic.ti.com
Power Mgmt	power.ti.com
Microcontrollers	microcontroller.ti.com
RFID	www.ti-rfid.com
OMAP Applications Processors	www.ti.com/omap
Wireless Connectivity	www.ti.com/wirelessconnectivity

Applications

Automotive and Transportation	www.ti.com/automotive
Communications and Telecom	www.ti.com/communications
Computers and Peripherals	www.ti.com/computers
Consumer Electronics	www.ti.com/consumer-apps
Energy and Lighting	www.ti.com/energy
Industrial	www.ti.com/industrial
Medical	www.ti.com/medical
Security	www.ti.com/security
Space, Avionics and Defense	www.ti.com/space-avionics-defense
Video and Imaging	www.ti.com/video

TI E2E Community

e2e.ti.com